

KIPOR

KIPOR POWER OPERATION MANUAL

PLEASE READ THIS MANUAL CAREFULLY.
IT CONTAINS IMPORTANT SAFETY INFORMATION.

WWW.KIPOR.COM

KIPOR

WUXI KIPOR POWER CO., LTD.

Address: Beside Jingyi Rd, Third-stage Development Section
of Wangzhuang Industry Area, Wuxi High &
New Technology Industry Development Zone.

TEL: 0086-510-85200888
FAX: 0086-510-85200999
E-MAIL: kipor@kipor.com



DIESEL GENERATOR

OPEN FRAME:

SINGLEPHASE: KDE7000E/EA
KDE11000E/EA
THREE PHASES: KDE8000E3/EA3
KDE12000E3/EA3

SILENT:

SINGLEPHASE: KDE7000T/TA
KDE11000T/TA
THREE PHASES: KDE8000T3/TA3
KDE12000T3/TA3

| | | | | | | | |
|----|---------------|-----------------------------|-----------------------|----------|--|--|--------|
| 24 | | | | | | | |
| 23 | | | | | | | |
| 22 | SA | Ignition switch | JK427 | 1 | | | |
| 21 | TC | Transformer | 220V/15V 40A | 1 | | | |
| 20 | | Charging adjustor | 35Ah | 1 | | | |
| 19 | GB | Battery | 6-QW-36 12V 36Ah 310A | 1 | | | |
| 18 | AVR (Digital) | Automatic voltage adjustor | | 1 | | | |
| 17 | L1 | Current transformer | 50/5mA | 1 | | | |
| 16 | SB | Emergency stop button | LAY37-11ZS | 1 | | | |
| 15 | W3 | Flywheel generator winding | | | | | |
| 14 | | | | | | | |
| 13 | W2 | Exciting winding | | | | | |
| 12 | W1 | Generating/Sampling winding | | | | | |
| 11 | BX2011C | Fuse link | 10A | | | | |
| 10 | BX2011C | Fuse link | 20A | | | | |
| 9 | FU2、FU3 | Four line fuse box | BX2041C | 1 | | | |
| 8 | FU1、FU4 | Fuse (extend 6X30) 10A | BX201C | 2 | | | |
| 7 | YV | Throttle electric magnet | | 1 | | | |
| 6 | KM1、KM2 | AC contactor | A26-40-00 | 2 | | | |
| 5 | K1、K2、K3 | Relay | HFV4 12V 20A | 3 | | | |
| 4 | | ATS module | PLY-MB-ATS-S1 | 1 | | | |
| 3 | | Digital display | PLY-MB-D | 1 | | | |
| 2 | | Digital module | PLY-MB3-ATS-C | 1 | | | |
| 1 | QF | Breaker | D50/1620 25A | 1 | | | |
| | Code name | Name | Material | Quantity | | | Remark |

PREFACE

Thank you for purchasing Kipor diesel generators.

This operation manual will tell you how to operate and service your KIPOR generator set correctly. Please read this manual before using the generator set to ensure the proper operation. Follow the instructions to keep your generator set in the best working condition and extend the life of it. If you have any comments or problem, please contact with our sales company or the authorized agent.

This manual deals with the general items of the KIPOR diesel generation set. However, the manual may vary with the development of the products in the future. Please give special attentions to warnings and cautions.



WARNING

Indicates that the severe personal injury even death will result if the instructions are not followed.



CAUTION

Indicates that the serious personal injury or equipment damage will result if the instructions are not followed.

KIPOR diesel generator set will meet your requirement if you operate it according to the manual instruction. Otherwise serious personal injury and equipment damage will result.

So, KIPOR reconfirms that you must to read and understand this manual before operating the generator set.

Three phases
 KDE8000EA3/TA3
 KDE12000EA3/TA3

ON/OFF Table for electric starting key

| | ① | ② | ③ | ④ | ⑤ |
|-------|---|---|---|---|---|
| OFF | | | | ○ | ○ |
| ON | ○ | ○ | | | |
| START | ○ | ○ | ○ | | |

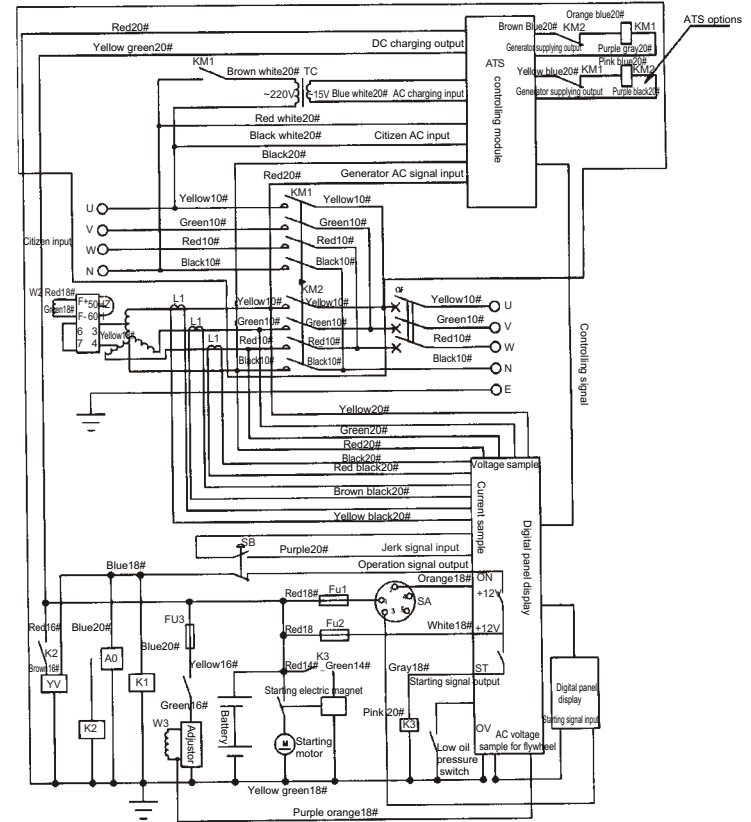

| | | | | | | | | | |
|----|---------------|-----------------------------|----------|-------------------------|--|--|--|--------------------------|--------|
| 24 | | | | | | | | | |
| 23 | X1_X2 | Receptacle | 2 | Honda or European style | | | | | |
| 22 | SA | Ignition switch | 1 | JK427 | | | | | |
| 21 | TC | Transformer | 1 | 220V/15V 40A | | | | | |
| 20 | | Charging adjustor | 1 | 35Ah | | | | | |
| 19 | GB | Battery | 1 | 6-QW-36 12V 36Ah 310A | | | | | |
| 18 | AVR (Digital) | Automatic voltage adjustor | 1 | | | | | | |
| 17 | L1 | Current transformer | 1 | 50/5mA | | | | | |
| 16 | SB | Emergency stop button | 1 | LAY37-11ZS | | | | | |
| 15 | W4 | Flywheel generator winding | | | | | | | |
| 14 | W3 | Secondary winding | | | | | | | |
| 13 | W2 | Exciting winding | | | | | | | |
| 12 | W1 | Generating/Sampling winding | | | | | | | |
| 11 | BX2011C | Fuse link | | 10A | | | | | |
| 10 | BX2011C | Fuse link | | 20A | | | | | |
| 9 | FU2、FU3 | Four line fuse box | 1 | BX2041C | | | | | |
| 8 | FU1、FU4 | Fuse (extend 6X30) 10A | 2 | BX201C | | | | | |
| 7 | YV | Throttle electric magnet | 1 | | | | | | |
| 6 | KM1、KM2 | AC contactor | 2 | A26-40-00 | | | | | |
| 5 | K1,K2,K3 | Relay | 3 | HFV4 12V 20A | | | | | |
| 4 | | ATS module | 1 | PLY-MB-ATS-S2 | | | | | |
| 3 | | Digital display | 1 | PLY-MB-D | | | | | |
| 2 | | Digital module | 1 | PLY-MB-ATS-C | | | | | |
| 1 | QF | Breaker | 1 | D50/1620 25A | | | | BeiYu electric appliance | Remark |
| | Code name | Breaker Name | Quantity | Material | | | | | |

Safety Information

WARNING

1. TO PREVENT THE FIRE

Never add fuel to the fuel tank while the engine is running.

Wipe off the overflowed fuel with a clean cloth. Keep explosives and other flammable products away from the generator set.

- To prevent the fire and to provide adequate ventilation, keep the generator set at least one meter away from buildings and other equipment during operation.
- Operate the generator set on a level surface.
- Do not put the generator set indoors while the engine is hot.

2. TO PREVENT FROM INHALING THE EXHAUST

Exhaust gas contains poisonous carbon monoxide, which is harmful to the health. Never use the generator set at the confined places or poor ventilated locations. If it's necessary to run the generator set indoors, be sure to provide the adequate ventilation.

3. BE CARE NOT TO BE SCALDED

The muffler and the engine body are very hot while the engine is running or just after running, do not touch these parts to prevent from being scalded.

4. ELECTRIC SHOCKS, SHORT CIRCUITS

To avoid electric shocks or short circuits, do not touch the generator set when your hands are wet. This generator set is not waterproof, so it should not be used in a place exposed to rain snow or water sprays. Use the generator set in a wet place can cause short circuits and electric shocks during operation.

- The generator set should be grounded to prevent electrical shocks from faulty appliances. Connect a length of heavy wires between the generator sets ground terminal and an external ground source.
- Do not hook up tools or other apparatus to generator set before it has been started. If equipment is attached, generator starting may cause sudden movements of the equipment and result in injuries and accidents. Be sure to disconnect any apparatus from the generator set or prior to starting.

⚠ CAUTION

- Most appliance motors require more than their rated wattage for start-up.
- Do not exceed the specified current limit of any socket.
- Do not connect the generator set to a household circuit. This could cause damage to the generator set and to electrical appliances in the house.

5. WHEN CHARGING THE BATTERY

Battery electrolyte contains sulfuric acid. Protect your eyes, skin and clothing. In case of contact, flush thoroughly with water and get prompt medical attention, especially if your eyes are affected. Batteries generate hydrogen gas, which can be highly explosive. Do not smoke or allow flames or sparks near a battery, especially during charging. Charge the battery in a fully ventilated place.

KDE11000E/EA Double voltage output

ON/OFF Table for electric starting key

| | ① | ② | ③ | ④ | ⑤ |
|-------|-----|-----|---|-----|---|
| OFF | | | | ○—○ | |
| ON | ○—○ | | | | |
| START | ○—○ | ○—○ | | | |

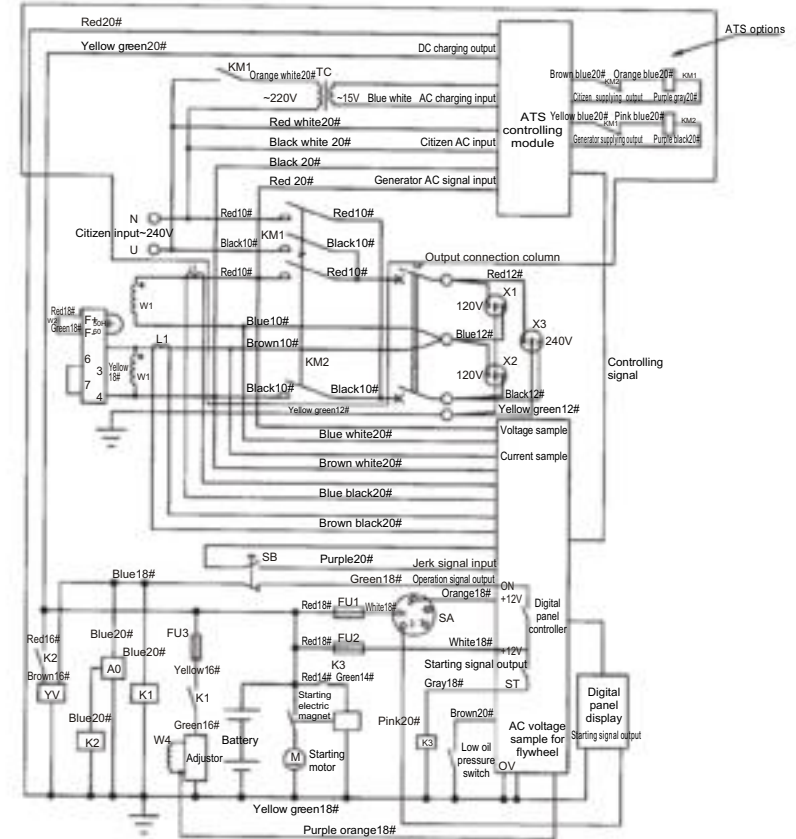

| | | | | | | |
|----|--------------|-----------------------------|----------|-------------------------|--------|--|
| 24 | | | | | | |
| 23 | X1 X2 | Receptacle | 2 | Honda or European style | | |
| 22 | SA | Ignition switch | 1 | JK427 | | |
| 21 | TC | Transformer | 1 | 220V/15V 40A | | |
| 20 | | Charging adjustor | 1 | 35Ah | | |
| 19 | GB | Battery | 1 | 6-QW-36 12V 36Ah 310A | | |
| 18 | AVR(Digital) | Automatic voltage adjustor | 1 | | | |
| 17 | L1 | Current transformer | 1 | 50/5mA | | |
| 16 | SB | Emergency stop button | 1 | LAY37-11ZS | | |
| 15 | W4 | Flywheel generator winding | | | | |
| 14 | W3 | Secondary winding | | | | |
| 13 | W2 | Exciting winding | | | | |
| 12 | W1 | Generating/Sampling winding | | | | |
| 11 | BX2011C | Fuse link | | 10A | | |
| 10 | BX2011C | Fuse link | | 20A | | |
| 9 | FU2, FU3 | Four line fuse box | 1 | BX2041C | | |
| 8 | FU1, FU4 | Fuse (extend 6X30) 10A | 2 | BX201C | | |
| 7 | YV | Throttle electric magnet | 1 | | | |
| 6 | KM1, KM2 | AC contactor | 2 | A26-40-00 | | |
| 5 | K1,K2,K3 | Relay | 3 | HFV4 12V 20A | | |
| 4 | | ATS module | 1 | PLY-MB-ATS-S1 | | |
| 3 | | Digital display | 1 | PLY-MB-D | | |
| 2 | | Digital module | 1 | PLY-MB-ATS-C | | |
| 1 | QF | Breaker | 1 | D50/1620 25A | | |
| | Code name | Name | Quantity | Material | Remark | |

CONTENTS

| | |
|--|----|
| 1.Main Technical Specifications and Data | 1 |
| 2.Parts Name | 3 |
| 3.Preparation for Starting | 6 |
| 4.Start the Generator Set | 9 |
| 5.Operate the Generator Set | 11 |
| 6.Load | 12 |
| 7.Stop the Generator Set | 15 |
| 8.Periodic Checks and Service | 16 |
| 9.Long-term Storage | 19 |
| 10.Troubleshooting and Remedy | 20 |
| 11.Electric diagram and wiring diagram | 21 |

KDE11000E/EA single phase

ON/OFF Table for electric starting key

| | ① | ② | ③ | ④ | ⑤ |
|-------|---|---|---|---|---|
| OFF | | | | ○ | ○ |
| ON | ○ | ○ | | | |
| START | ○ | ○ | ○ | | |

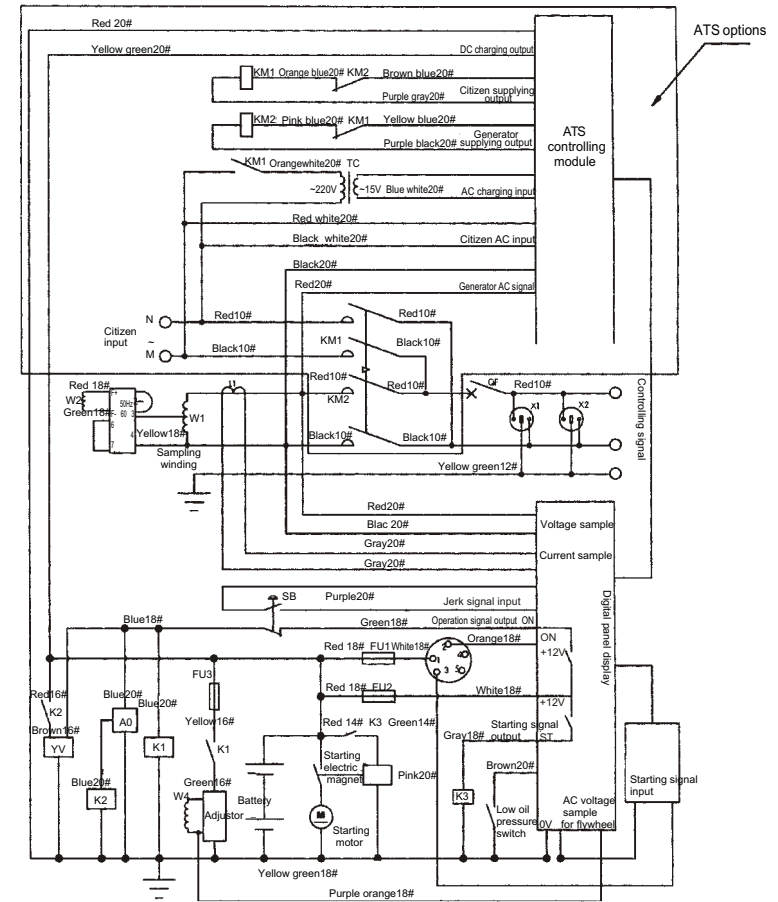

| | | | | | |
|----|---------------|-----------------------------|----------|-------------------------|--------------------------|
| 24 | X3 | DC receptacle | 1 | DC12V 8.3A | |
| 23 | X1 X2 X3 | Receptacle | 3 | Honda or European style | |
| 22 | SA | Ignition switch | 1 | JK427 | |
| 21 | TC | Transformer | 1 | 220V/15V 40A | |
| 20 | | Charging adjuster | 1 | 35Ah | |
| 19 | GB | Battery | 1 | 6-QW-36 12V 36Ah 310A | |
| 18 | AVR (Digital) | Automatic voltage adjuster | 1 | | |
| 17 | L1 | Current transformer | 1 | 50/5mA | |
| 16 | W5 | User charging winding | | | |
| 15 | W4 | Flywheel generator winding | | | |
| 14 | W3 | Secondary winding | | | |
| 13 | W2 | Exciting winding | | | |
| 12 | W1 | Generating/Sampling winding | | | |
| 11 | BX2011C | Fuse link | | 10A | |
| 10 | BX2011C | Fuse link | | 20A | |
| 9 | FU2、FU3 | Four line fuse box | 1 | BX2041C | |
| 8 | FU1、FU4 | Fuse (extend 6X30) 10A | 2 | BX201C | |
| 7 | YV | Throttle electric magnet | 1 | | |
| 6 | KM1、KM2 | AC contactor | 2 | A26-40-00 | |
| 5 | K1,K2,K3 | Relay | 3 | HFV4 12V 20A | |
| 4 | | | | PLY-MB-ATS-S1 | |
| 3 | | Digital display | 1 | PLY-MB-D | |
| 2 | | Digital module | 1 | PLY-50MB-2C | |
| 1 | QF | Breaker | 1 | D50/1620 25A | BeiYu electric appliance |
| | Code name | Name | Quantity | Material | Remark |

1.MAIN TECHNICAL SPECIFICATINS AND DATA

Single-phase diesel generator

| Model | KDE7000E/EA | KDE7000T/TA | KDE11000E/EA | KDE11000T/TA |
|----------------------------------|---|-------------|--------------|--------------|
| Rated frequency | 50 | 60 | 50 | 60 |
| Rated output | 5.6 | 6.2 | 8.5 | 9.5 |
| Max. output | 6 | 6.8 | 9.5 | 10.5 |
| Rated voltage | 115/230 | 120/240 | 115/230 | 120/240 |
| Rated current | 48.7/24.3 | 51.7/25.8 | 73.9/36.9 | 79.2/39.6 |
| Rated rotation speed | 3000 | 3600 | 3000 | 3600 |
| Phase NO./Excitation mode | Single phase, three loops / Self-excitation and constant voltage(AVR) | | | |
| Power factor (cos φ) | 1.0 | | | |
| Insulation Grade | F | | | |
| Pole number | 2 | | | |
| DC output | 12V/8.3A Without | | | |
| Working type | 12 hours continuous running | | | |
| Engine Model | KD2V78F | | | |
| Engine Type | Two cylinder, V style, air cooled, four stroke, direct injection | | | |
| Cylinder NO.-bore × stroke mm | 78 × 62 86 × 72 | | | |
| Displacement L | 0.610 0.836 | | | |
| Compression ratio | 20 : 1 19 : 1 | | | |
| Rated power [kW/(r/min)] | 6.6/3000 7.2/3600 10.3/3000 11.3/3600 | | | |
| Fuel type | Diesel(Off(summer)-10#(winter)-35#(cold)) | | | |
| Lube oil brand | L-ECD grade 15W30 or 15W40 | | | |
| Fuel consumption g/KWh | ≒ 340 ≒ 340 | | | |
| Fuel tank capacity L | 25 25 | | | |
| Continuous running time h | 11 9.5 7 6.5 | | | |
| Overall dimension: L × W × H(mm) | T/TA: 1056 × 630 × 820 E/EA: 920 × 560 × 645 T/TA: 1136 × 650 × 860 E/EA: 930 × 620 × 690 | | | |
| Dry weight(kg) | E/EA:155 T/TA:220 E/EA:185 T/TA:265 | | | |
| Starting system | 12 V Electric starter 12 V Electric starter | | | |
| Structure type | E/EA:Open frame T/TA:Silent | | | |

NOTE: A is a digital panel

Three-Phase diesel generator

| Model | KDE8000E3/EA3 | | KDE8000T3/TA3 | | KDE12000E3/EA3 | | KDE12000T3/TA3 | |
|-----------------------------------|--|---------|---------------|---------|----------------|---------|----------------|--|
| | 60 | 60 | 60 | 60 | 50 | 60 | 60 | |
| Rated frequency | 6.6 | 7.2 | 6.6 | 7.2 | 5.0 | 6.0 | 6.0 | |
| Rated output | 5.3 | 5.75 | 6.6 | 7.2 | 9.5 | 10.5 | 10.5 | |
| Max. output | 7.2 | 7.9 | 5.3 | 5.75 | 7.6 | 8.4 | 8.4 | |
| Rated voltage | 400/230 | 416/240 | 400/230 | 416/240 | 400/230 | 416/240 | 416/240 | |
| Rated current | 9.5 | 10 | 9.5 | 10 | 13.7 | 14.6 | 14.6 | |
| Rated rotation speed | 3000 | 3600 | 3000 | 3600 | 3000 | 3600 | 3600 | |
| Phase NO./Excitation mode | Three phase four line,"Y" connection | | | | | | | |
| Power factor (cosφ) | 0.8(lag) | | | | | | | |
| Insulation Grade | F | | | | | | | |
| Pole number | 2 | | | | | | | |
| DC output | 12V/8.3A | | | | | | | |
| Working type | 12 hours continuous running | | | | | | | |
| Engine Model | KD2V78F | | | | | | | KD2V86F |
| Engine Type | Two cylinder, V style, air cooled, four stroke, direct injection | | | | | | | Two cylinder, V style, air cooled, four stroke, direct injection |
| Cylinder NO.-bore × stroke mm | 78×62 | | | | | | | 86×72 |
| Displacement L | 0.610 | | | | | | | 0.836 |
| Compression ratio | 20 : 1 | | | | | | | 19 : 1 |
| Rated power [kW]/(r/min)] | 6.6/3000 | | | | | | | 10.3/3000 |
| Fuel type | Diesel(O#(summer),-10#(winter),-35#(cold)) | | | | | | | |
| Lube oil brand | L-ECD 级 15W30 or 15W40 | | | | | | | |
| Fuel consumption g/KW.h | ≅ 340 | | | | | | | ≅ 340 |
| Fuel tank capacity L | 25 | | | | | | | 25 |
| Continuous running time h | 11 | | | | | | | 7 |
| Overall dimension: L × W × H (mm) | T3/TA3: 1056×630×820 E3/EA3: 920×560×645 | | | | | | | T3/TA3: 1056×630×820 E3/EA3: 920×560×645 |
| Dry weight(kg) | E3/EA3:155 T3/TA3:220 | | | | | | | E3/EA3:185 T3/TA3:265 |
| Starting system | 12 V Electric starter | | | | | | | 12 V Electric starter |
| Structure type | E3/EA3:Open frame T3/TA3:Silent | | | | | | | |

NOTE: A is digital panel

KDE 7000E/EA double-voltage optional output

ON/OFF Table for electric starting key

| | ① | ② | ③ | ④ | ⑤ |
|-------|---|---|---|---|---|
| OFF | | | | | |
| ON | ○ | ○ | | ○ | ○ |
| START | ○ | ○ | ○ | | |

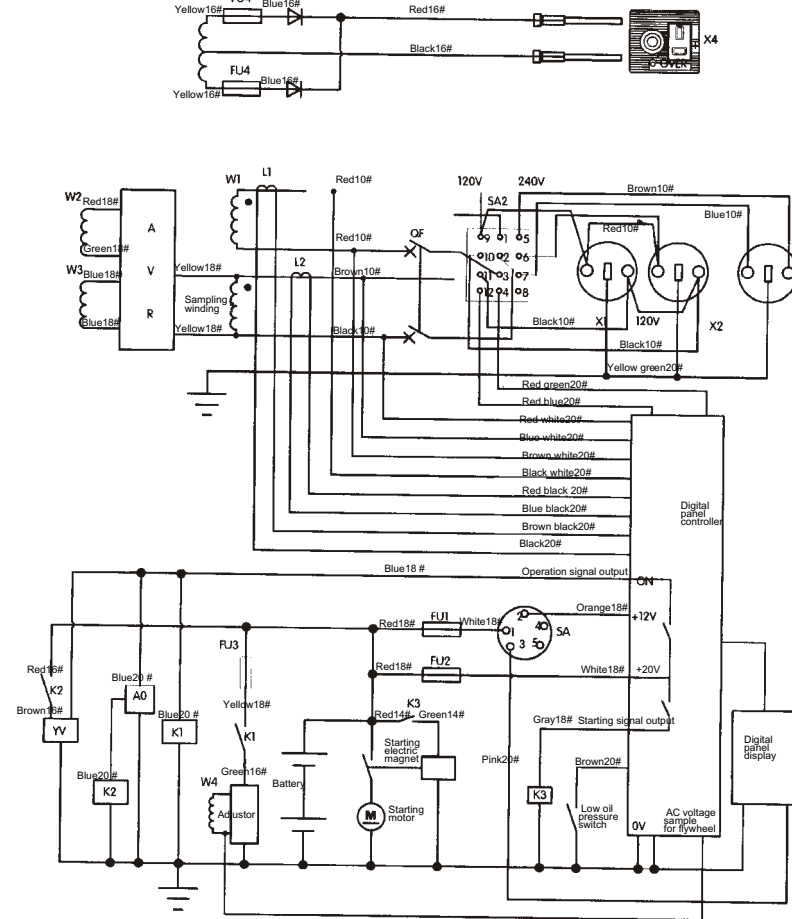

| | | | | | |
|----|---------------|-----------------------------|----------|-------------------------|-------------------------|
| 24 | X3 | DC receptacle | 1 | DC12V 8.3A | |
| 23 | X1 X2 | Receptacle | 2 | Honda or European style | |
| 22 | SA | Ignition switch | 1 | JK427 | |
| 21 | TC | Transformer | 1 | 220V/15V 40A | |
| 20 | | Charging adjuster | 1 | 35Ah | |
| 19 | GB | Battery | 1 | 6-QW-36 12V 36Ah 310A | |
| 18 | AVR (Digital) | Automatic voltage adjuster | 1 | | |
| 17 | L1 | Current transformer | 1 | 50/5mA | |
| 16 | W5 | User charging winding | | | |
| 15 | W4 | Flywheel generator winding | | | |
| 14 | W3 | Secondary winding | | | |
| 13 | W2 | Exciting winding | | | |
| 12 | W1 | Generating/Sampling winding | | | |
| 11 | BX2011C | Fuse link | | 10A | |
| 10 | BX2011C | Fuse link | | 20A | |
| 9 | FU2、FU3 | Four line fuse box | 1 | BX2041C | |
| 8 | FU1、FU4 | Fuse (extend 6X30) 10A | 2 | BX201C | |
| 7 | YV | Throttle electric magnet | 1 | | |
| 6 | KM1、KM2 | AC contactor | 2 | A26-40-00 | |
| 5 | K1,K2,K3 | Relay | 3 | HFV4 12V 20A | |
| 4 | | ATS module | 1 | PLY-MB-ATS-S1 | |
| 3 | | Digital display | 1 | PLY-MB-D | |
| 2 | | Digital module | 1 | PLY-MB-ATS-C | |
| 1 | QF | Breaker | 1 | D50/1620 25A | BeYu electric appliance |
| | Code name | Name | Quantity | Material | Remark |

2. PARTS NAME

2.1 Parts name (E/EA, E3/A3 Type)

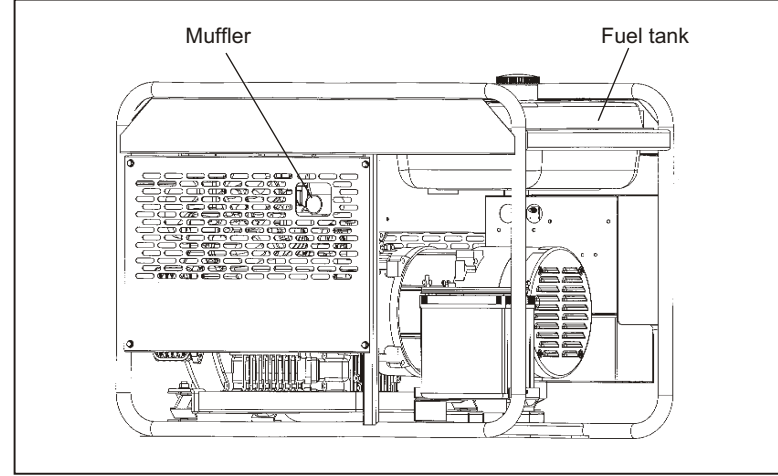
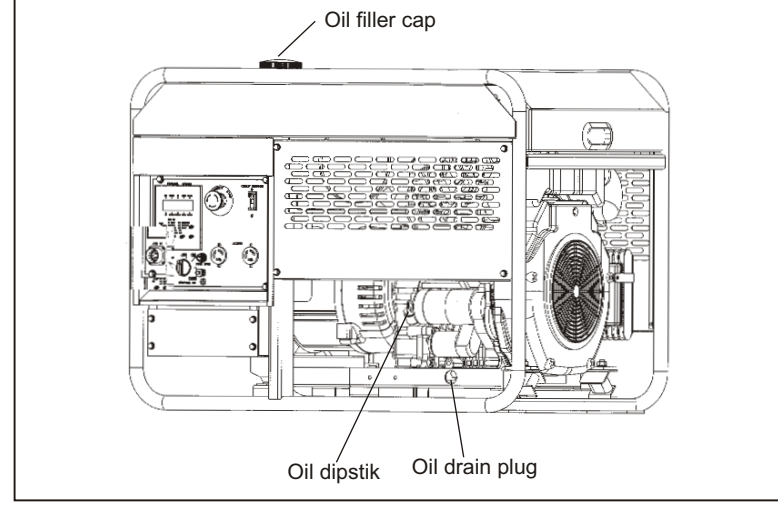

2.1 Parts name (T/TA, T3/TA3 type)

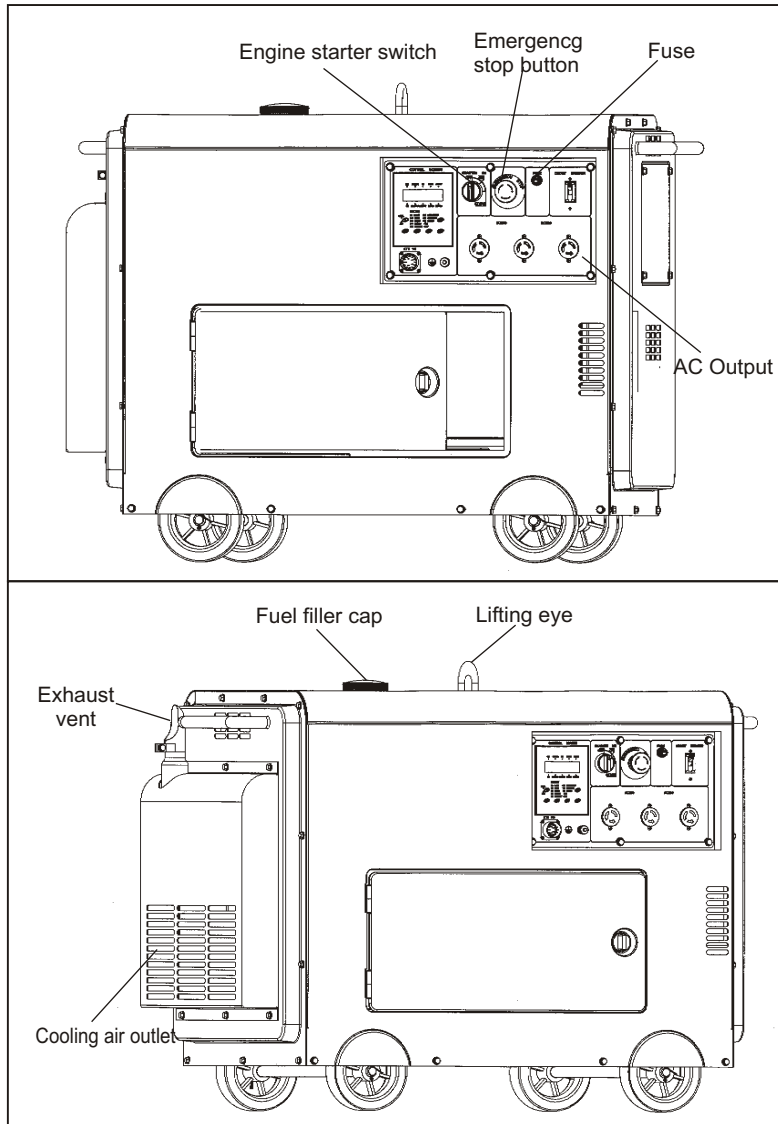

11. ELECTRIC SCHEMATIC DIAGRAM AND ELECTRIC WIRING DIAGRAM

KDE7000E/EA single phase

OFF and ON table for electric starting key:

| | ① | ② | ③ | ④ | ⑤ |
|-------|---|---|---|---|---|
| OFF | | | | | |
| ON | ○ | ○ | | ○ | ○ |
| START | ○ | ○ | ○ | | |

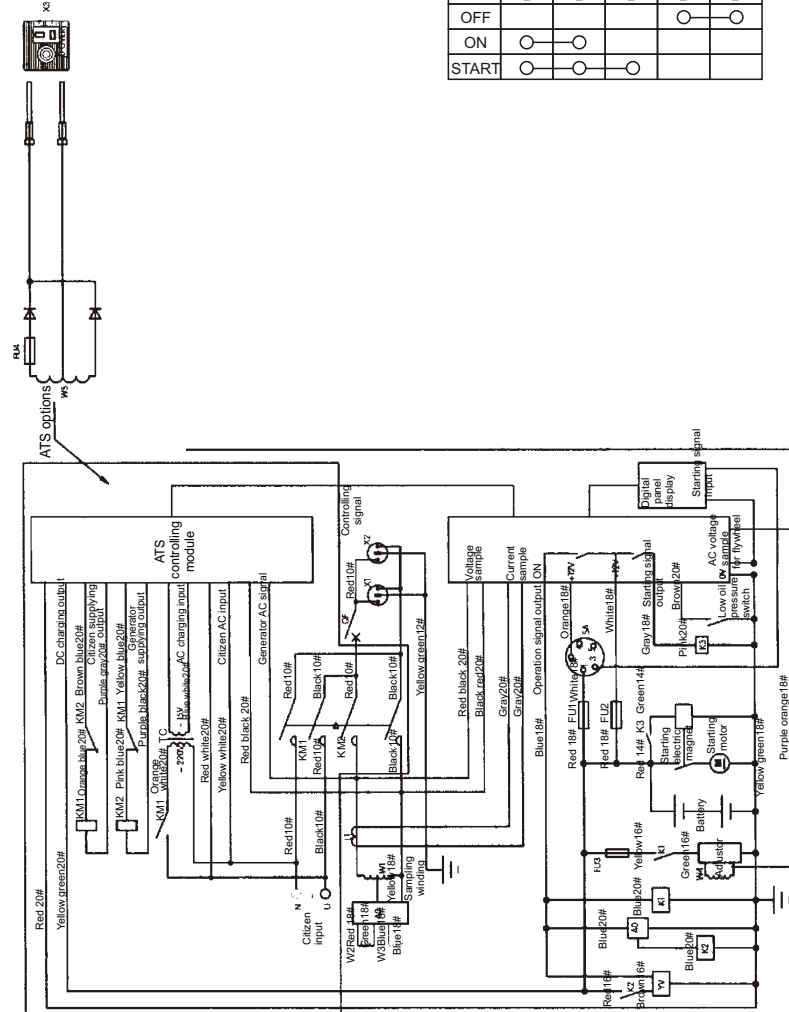

10. TROUBLESHOOTING

| Fault | Troubleshooting |
|--|---|
| Engine can't start or fuel is not sufficient | Refill |
| The switch is not at START position | Turn it to START position |
| The fuel injection pump and nozzle don't deliver the fuel or deliver insufficient fuel | Remove the nozzle and repair it at test table |
| Check the engine oil level | The specified oil level should be between the upper level and lower level |
| The nozzle is dirty | Clean the nozzle |
| The battery has no electricity | Charge or replace it |
| Insufficient oil and low rotation speed | Adjust the throttle bolt and fill in oil |
| Generator sets can't work and the main switch is off | Turn on the main switch |
| The carton brush already worn | Replace the carton brush |
| Bad receptacle contact | Adjust the receptacle |

2.2 Control panel

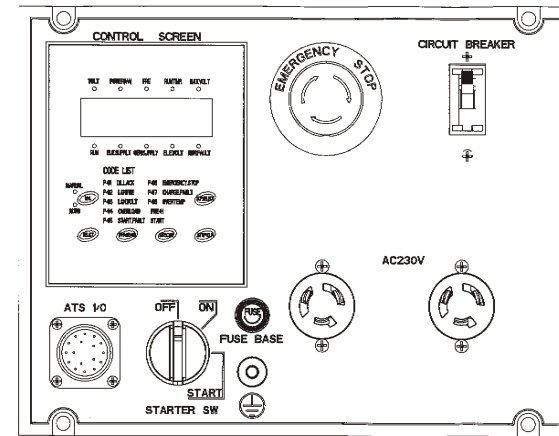

EA type panel

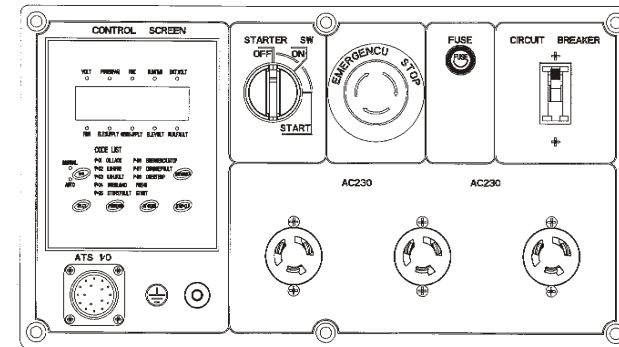

TA type panel

3. PREPARATION FOR STARTING

3.1 Selection and using of the fuel

■ Selection of fuel

Only use the light diesel, which is most suitable for the engine.

■ Keep dust and water out of the fuel

When filling the fuel tank from drums, make sure that no dust or water is mixed in the fuel. Otherwise the serious fuel injection pump and nozzle problems will result.

■ Do not overfill

Overfilling is very dangerous. Do not fill the tank beyond the top of the red plug inside the fuel filter.

WARNING

- Refuel in a well-ventilated area with the engine stopped.
- Do not smoke or allow flames or sparks in the area where the engine is refueled or where the fuel stored.
- Do not overfill the tank, make sure the filler cap is securely closed after refueling.
- Be careful not to spill fuel when refueling. If any fuel is spilled, make sure the area is dry before starting the engine

3.2 Check and refill the oil

WARNING

- Always check the oil level with the generator set on a level surface before starting and refill if necessary.
- The engine may be damaged if operated with insufficient oil, it is also dangerous to refill too engine oil as sudden increase in engine speed may be caused by its combustion.

CAUTION:

KIPOR KDE series generator set are equipped with low oil alarm system. This system will stop the engine automatically when the oil level falls below the lower level. This prevents accidents such as bearing seizures, etc.

9. LONG-TERM STORAGE

Do the following preparations for long-term storage:

- 1.Run the generator for 3 minutes and then stop.
- 2.If the generator is still hot after stop running, please drain out the original oil and fill in fresh oil.
- 3.Screw off the bolt of cylinder cover, fill in 2CC oil and tighten the bolt.
- 4.Clean the generator and store it in dry area.

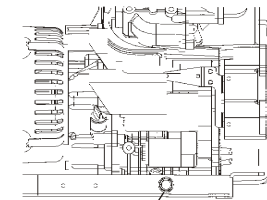

Drain oil bolt

1. Drain out the fuel from the fuel tank.
2. Drain out the fuel from the fuel tank.
Screw off the small screw of the fuel cock and pull out the filter from the filler port.
3. Wash the filter thoroughly with diesel fuel.
Loosen the fastening nut, bottom cover and delivery discs for cleaning the deposit carbon.
- 8.5 Tighten cylinder head bolt
Tightening the cylinder head bolt requires a special tool. Do not try yourself. Contact with KIPOR agent.
- 8.6 Check the injection nozzle and fuel injection pump
 1. Adjust the clearance of the intake/exhaust valves.
 2. Grind the intake/exhaust valves.
 3. Replace the piston ring

⚠ WARNING

■ Do not perform the injection nozzle test near an open fire or any other kind of fire. The fuel spray may ignite. Do not expose bare skin to the fuel spray. The fuel may penetrate the skin and cause injury to the body. Always keep your body away from the nozzle.

- 8.7 Check and refill the battery electrolyte and charge the battery
The diesel uses a 12V battery. Battery electrolyte will be lost through continuous charging and discharging.
Before starting, check for physical damage to the battery and also the electrolyte levels, and refill the distilled water till to the upper lever if necessary. When actual damage is discovered, replace the battery.
Check the battery electrolyte monthly.

⚠ WARNING

■ The battery electrolyte contains sulfuric acid. Protect your eyes, skin and clothing. In case of contact, flush thoroughly with water and get prompt medical attention, especially if your eyes are affected.
■ The battery exhaust hydrogen gas, which can be highly explosive. Do not smoke or allow flames or sparks near the battery, especially during charging.

- Select the most applicable oil
It is very important to select the applicable oil in order to keep up the performance and life of the generator set. If inferior oil is used, or if your oil is not replaced periodically, the risk of piston seizure, piston ring sticking and accelerated wear of the cylinder liner, bearing and other moving components will increase significantly. So the generator set life will be shortened. KIPOR recommends CC/CD oil classified by API. Choose the applicable viscosity oil according to the local ambient temperature.

- 3.3 Check the air cleaner
1. Screw off the wing nut, remove the air cleaner cover and take out the element.

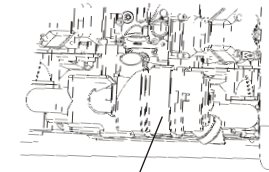

Air cleaner

⚠ CAUTION:

- Do not wash the element with detergent.
- Replace the element when its output decrease or a bad exhaust color is noticed.
- Never run the generator set without the element, otherwise the rapid engine wear will result.

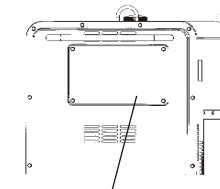

Air cleaner cover

2. Reattach the air clearer cover and screw on the wing nut.

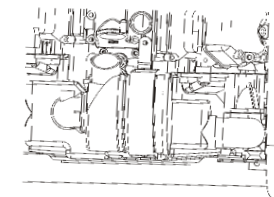

Element

3.4 Check the generator set

1. Turn off the main switch and any other loads.

⚠ WARNING:

- Be sure to turn off the main switch before starting.
- The generator set should be earthed to prevent electric shocks.

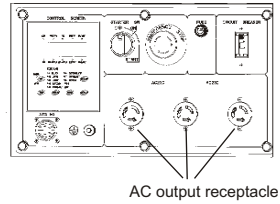

⚠ WARNING:

- The generator set should be earthed to prevent electric shocks.

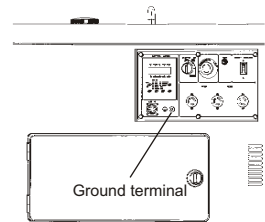
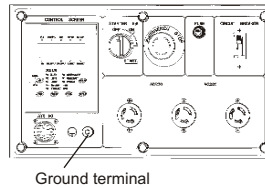

2. Use dual voltage type generator sets

Be sure to place the changeover switch in the correct position for the rated voltage of the working instrument.

⚠ CAUTION:

- Before starting the engine, be sure to turn the switches of the control panel (lighting apparatus, motor, etc.) to their "OFF" position. If the switches are not in the "OFF" position, the sudden application of load when the engine is started could be very dangerous.

8.1 Replace engine oil

Remove the oil filler cap. Remove the drain plug and drain the old oil while the engine is still warm. The plug is located on the bottom of the cylinder block. Tighten the drain plug and refill with the recommended oil.

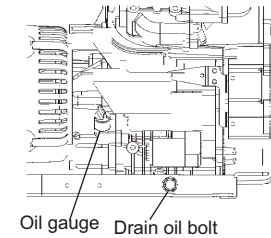

8.2 Clean the engine oil filter

| | |
|----------------------|-----------------------------|
| Cleaning time | Every 6 months or 500 hours |
| Replace if necessary | |

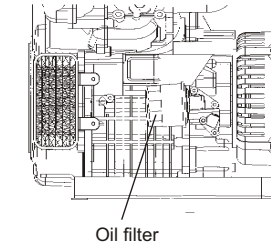

| | |
|---------------|-----------------------------|
| Cleaning time | Every 6 months or 500 hours |
|---------------|-----------------------------|

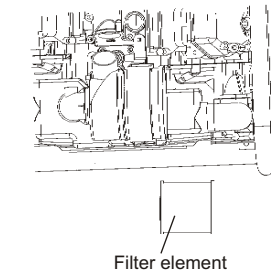

⚠ CAUTION

- Never run the engine without the element or with a defective element.

8.4 Clean and replace fuel oil filter

The fuel oil filter also has to be cleaned regularly to insure maximum engine output.

| | |
|--------------|---------------------------|
| Clean time | Every 6 months or 500 hrs |
| Replace time | Every year or 1000 hrs |

8. PERIODIC CHECK AND SERVICE

Periodic check and service are very important for keeping the engine in good condition and durable. The chart below indicates what checks to make and when to make them.

⚠ WARNING

- Shut off the engine before performing any service. If the engine must be run, make sure the area is well ventilated. The exhaust contains poisonous carbon monoxide gas.
- After the generating set has been used, clean it immediately with a cloth to prevent

8.1 Maintenance table:

| Item | Intervals | Every month | First month or 20 Hrs | Third month or 100 Hrs | Sixth month or 500 Hrs | Every year or 1000 Hrs |
|---|--|-------------|-----------------------|------------------------|-----------------------------------|------------------------|
| Check and refill oil | | ○ | | | | |
| Drain out fuel oil | | | ○ | | | |
| Check and refill engine oil | | ○ | | | | |
| Check for oil leakage | | ○ | | | | |
| Check and tighten fastening parts | ○ | | | | ● Tighten the cylinder head bolts | |
| Replace engine oil | | | ○ (First time) | ○ (After second time) | | |
| Clean engine oil filter | | | | | ○ (Replace if necessary) | |
| Replace air cleaner element | shorter maintenance period for dusty area | | | | ○ (Replace) | |
| Clear fuse element | | | | | ○ | ● |
| Check fuel injection pump | | | | | ● | |
| Check nozzle | | | | | ● | |
| Check fuel pipe | | | | | ● | |
| Adjust clearance of intake/exhaust valves | | | ● | | ● | |
| Grind intake/exhaust valves | | | | | | ● |
| Replace piston ring | | | | | | ● |
| Check battery electrolyte | Every month | | | | | |
| Check carbon brush and slip ring | | | | | ● | |
| Check insulation resistance | The generating set has been stored more than 10 days ○ | | | | | |

Note: "●" indicates that special tools are required, please contact with KIPOR agent.

3.5 How to open the cabinet door and covers of the silent generator set.

1. Turn the lever clockwise and open the cabinet door for daily inspection.
2. Loosen the bolt of the air cleaner check port cover to check the air cleaner.
3. Screw off the wing nut to open the cover of nozzle, then check the nozzle.

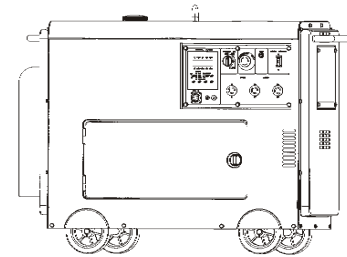

3.6 Break-in period operation

The first 20hrs are the break-in period of the engine, the operator must obey to following items:

- Warm up the engine 5 minutes after the initial starting. Run the engine at low speed and zero load before the engine becomes warm.
- Avoid applying any heavy loads during the break-in period. KIPOR recommends to run the engine at 3000r/min with 50% load in break-in period.
- Replace the oil on time.

Replace the oil while the engine is warm after 20-hours-running, the old oil will be drained out completely.

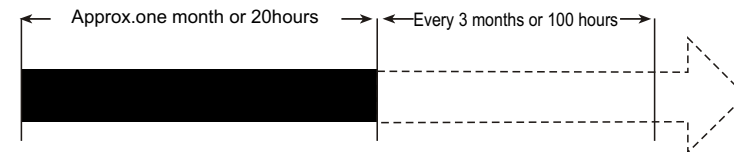

4. START THE GENERATOR SET

⚠ WARNING

- DO not hook up tools or other apparatus to the generator set before starting.

⚠ WARNING

■ Please tighten the screw on the cylinder to prevent any rainwater&dust,which may cause wearing of inner parts as well as break-downs

4-1 Recoil starting

1.Start the engine according to the following procedures:

- Open the fuel cock.
- Set the engine speed lever at the RUN position.
- Remove hands from the startor switch after the engine started , and the switch will return to the RUN position automatically.
- It will spend 10s to start, if the engine doesn't start after 10s, please wait 15s to restart it.

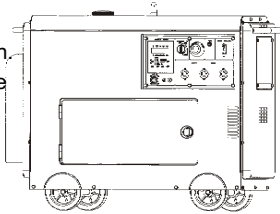

Start switch

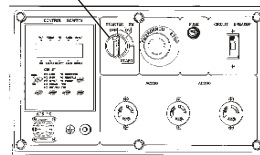

⚠ CAUTION

■ Running the starter motor for long time, it may consume the power, even destroy the battery.
■ Put the start switch at the "ON" position while the engine is running.

2. Battery

You must check the electrolyte each month, if the electrolyte level is below the lower limit line, please add the water to the upper limit line.

⚠ CAUTION

■ If the electrolyte is too little, the engine will not start. While if the electrolyte is too much, the electrolyte will corrupt the parts. You should keep the electrolyte level between the lower limit and upper limit.

7. STOP THE GENERATOR SET

7.1 Stop the generator set normally

1. Cut off the load
2. Turn off the air switch of the generator set
3. Turn off the engine switch, and turn the engine switch to "OFF" position

⚠ CAUTION

■ In the case that the speeds handle is on "Stop" position, while the engine is still running. You should turn the fuel switch to the "OFF" position, or loose the high pressure oil pipe bolt to stop the engine.
■ Don't stop the engine with load; you should cut off the load first.









7.2 Emergency shut down

1. While the set is running, the operator should keep close watch on the running state of the set. If there is anything abnormal, you should stop the set following the right procedure.
2. If there is any emergency, it will result in big destroy or personal accident, such as the set overspeed, short circuit, electric shock and so on. The operator should stop the generator decidedly. Press the"emergency stop button", and the generator will stop immediately.
3. Revolving the "emergency stop button" according to the arrow direction to replace it.

⚠ CAUTION

■ Don't use the "emergency stop button" in usual cases, which will do certain harm to your generator.

6.3 Electrical appliance particularly motor-driven equipment will produce very high current while starting, the below table provides the reference for connecting these apparatus to the generator set.

| TYPE | WATTAGE | | TYPICAL APPLIANCE | EXAMPLE | | |
|--|---------|--------|---|---|---------------|-----------|
| | STARTIN | GRATED | | APPLIANCE | STARTIN | GRATED |
| <ul style="list-style-type: none"> Incandescent lamp Heating appliance | X1 | X1 |  Incandescent lamp  TV |  Incandescent lamp 100W | 100VA (W) | 100VA (W) |
| <ul style="list-style-type: none"> Fluorescent lamp | X2 | X1.5 |  Fluorescent lamp |  Fluorescent lamp 40W | 80VA (W) | 60VA (W) |
| <ul style="list-style-type: none"> Motor driven equipment | X3~5 | X2 |  Refrigerator  Electric fan |  Refrigerator 150W | 450-750VA (W) | 300VA |
| <ul style="list-style-type: none"> switch power Rectify power | X2 | X2 | Motor , Electric drill , Computer UPS power | Computer UPS power 200W | 400VA | 400VA |

5. OPERATE THE GENERATOR SET

5.1 Operate the generator set

- Warm up the engine without load three minutes.
- Concerning the generator set with Low Oil Alarm System, check that the Low oil alarm Lamp is not lit.

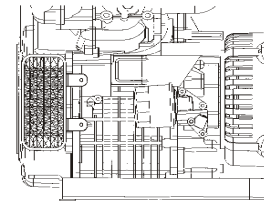
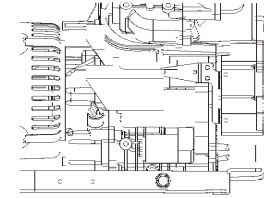

CAUTION

- For the generator set with Low Oil Alarm System, the Oil Alarm Lamp will activated by low oil pressure or engine oil shortage, simultaneously, the engine will stop. The engine will stop immediately if restarted without refilling the engine oil. Check the oil level and refill.
- Do not loosen or readjust either the engine speed limiting bolt or fuel injection limiting bolt, the performance will be affected.

5.2 Checks during the running

- Whether there is abnormal sound or vibration;
- Whether the engine misfires or runs rough;
- Check the color of the exhaust. (Is it black or too white?)

If you notice any of the above-mentioned phenomenon happened, stop the engine and find out the fault cause or contact with KIPOR agent.

CAUTION

- If the engine has been running, the muffler will be very hot. Be careful not to touch the muffler.
- Never refill the fuel tank while the engine is running.

6. LOAD

⚠ CAUTION

- Do not start 2 or more machines simultaneously. Start them one by one.
- Do not use floodlights together with other machines.
- First start the motor load, and then start resistance load.

6.1 AC application

1. Be sure to run the generator set at rated speed, otherwise AVR (Automatic Voltage Regulator) will produce the forced excitation. If the running is for a long time under such condition, AVR will be burned out.
 2. After switching on the air switch, observe the voltmeter on the panel of the control cabinet, the voltmeter should point to $230V \pm 5\%$ (50Hz) for single-phase generator set; $400V \pm 5\%$ (50Hz) for three-phase generator set, then the loading can be carried out.
 3. When the double voltage generator set changes over the voltage, the air switch should be set at "OFF" position. Otherwise the generator set and electric devices will be burned out and damaged.
 4. Connect the equipment to the generator set in order. For the matter of the motor load, firstly the heavy-duty motor should be connected, then the light-duty motors. If the operation is false, the generator set will lag or stop suddenly. It is necessary to unload the generator set immediately and turn off the main switch and do checks.
5. Three-phase generator set
- Balance three phases during the operation. Stop the engine for check if the tolerance exceed 20%. Be sure to keep the tolerance among three phases less than 20%
 - The load for each phase must below the rated load as well as the current must less than rated current.
A,B,C,D(or U,V,W,N) phase arrangement should be from left to right, or clockwise.
 - Concerning starting the three phase asynchronous motors, first start the heavy-duty motors, then start the light-duty motors.

⚠ NOTE

- If overloading of the circuit trips the AC circuit protector, reduce the electrical load on the circuit, and wait a few minutes before resuming operation.

6.2 DC application

1. DC terminals are only for charging 12V battery.
2. Set the air switch at "OFF" position while charging. On the 12V output terminals, a charge switch can be connected so the switch can be used for on-and-off purpose.
3. Concerning the automatic type battery with the leads, be sure to disconnect the negative leads of the battery while charging.

⚠ CAUTION

- Connect the positive and negative poles of the battery with the positive and negative poles of DC terminals separately. Do not confuse them, otherwise the battery and generator set will burn out.
- Do not connect the positive pole of the battery with its negative pole, otherwise the battery damage will result.
- Do not connect the positive pole of the DC terminal with its negative pole, otherwise the generator set damage will result.
- When a large capacity battery is charged, excessive current flows, the fuse for the direct current will burn out.
- Do not run the generator set while it is still connected with the battery.
- Do not use DC12V and AC at the same time.

⚠ CAUTION

- Battery exhausts explosive gas. Keep sparks, flames, and cigarettes away from the battery. To prevent from creating a spark near the battery, always connect the charging cables to the battery first and only then to the generator set. When disconnecting, you should disconnect the cables at the generator set first.
- Charge the battery at a well-ventilated place.
- Before charging, remove the cap from each cell of the battery.
- Stop charging if the electrolyte temperature exceed 45°C